

Quick-Fold Screen Frames User's Guide



Focupix

Please always follow the instruction on user's guide in assembling and usage.

PROCEDURE

Frames and legs are made of 1-3/8" square hard aluminum tubing with an anodized finish. With proper care they will provide many years of use. Please follow the set up instructions below.

Two Section Frame

1. Remove the frame from its case and wrapping. Position it as shown (fig 1).
2. Unfold the frame following the directions given below so that it is lying flat, Snap latches will automatically lock (as fig 2).
3. While holding the bottom of the frame in place, lift the top of the frame to unfold the sides. Lock down all four corner braces (as fig 3).

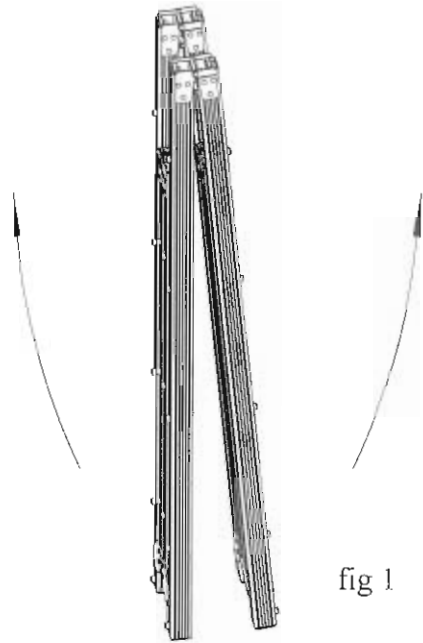

fig 1



fig 2

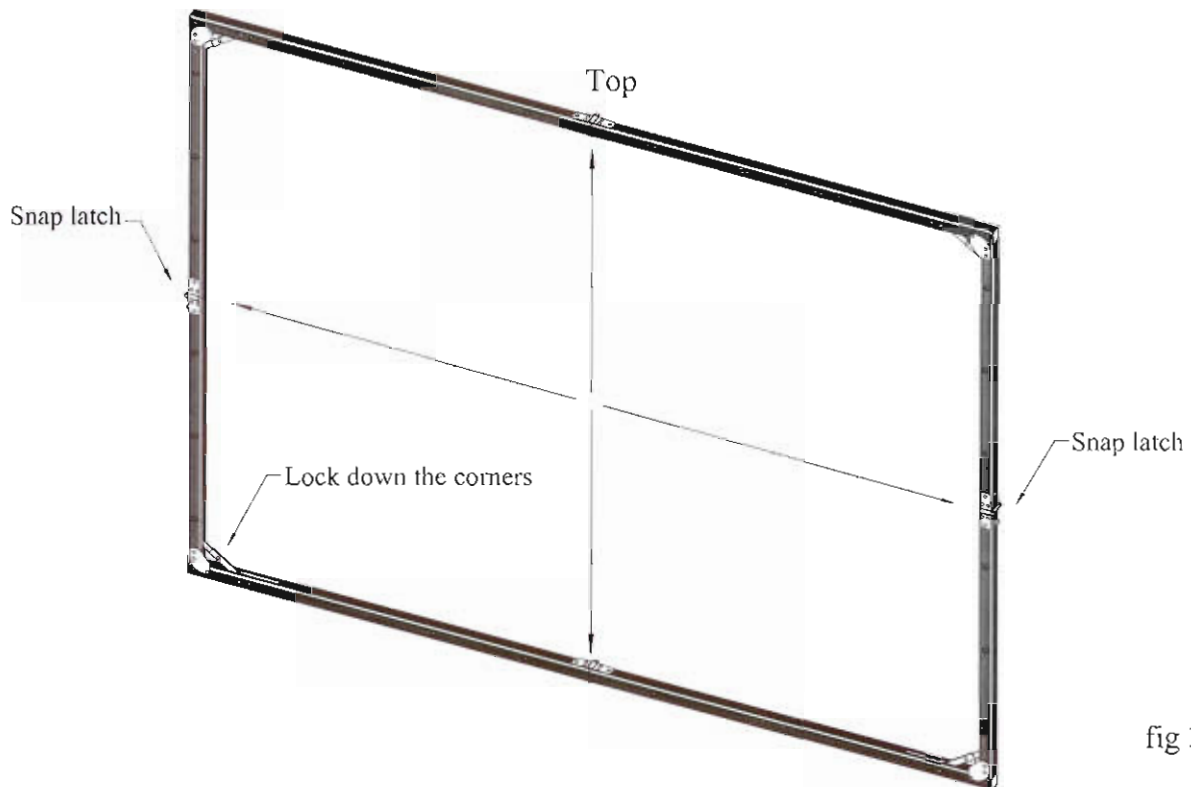

fig 3

Three Section Frame

1. Remove the frame from its case and wrapping. Position it as shown (fig 4).
2. Unfold the frame following the directions given below so that it is lying flat. Snap latches will automatically lock (as fig 5).
3. While holding the bottom of the frame in place, lift the top of the frame to unfold the sides. Lock down all four corner braces (as fig 6).

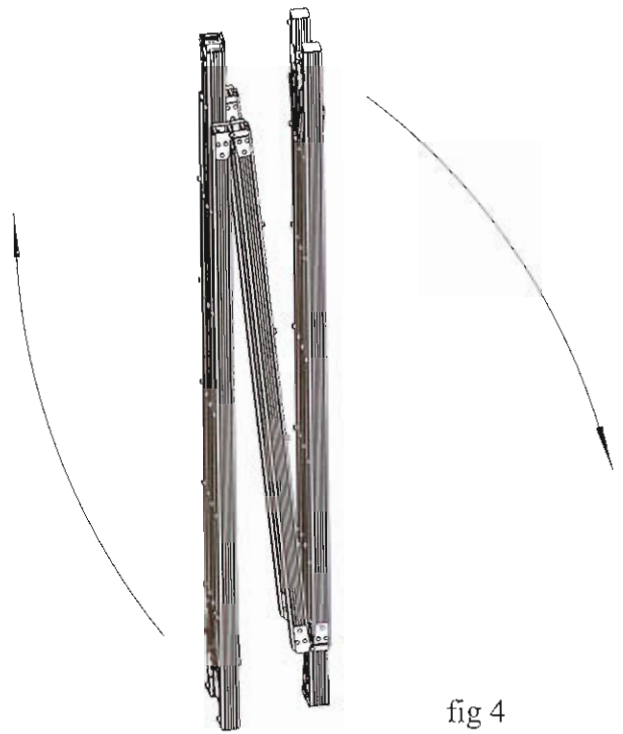

fig 4



fig 5

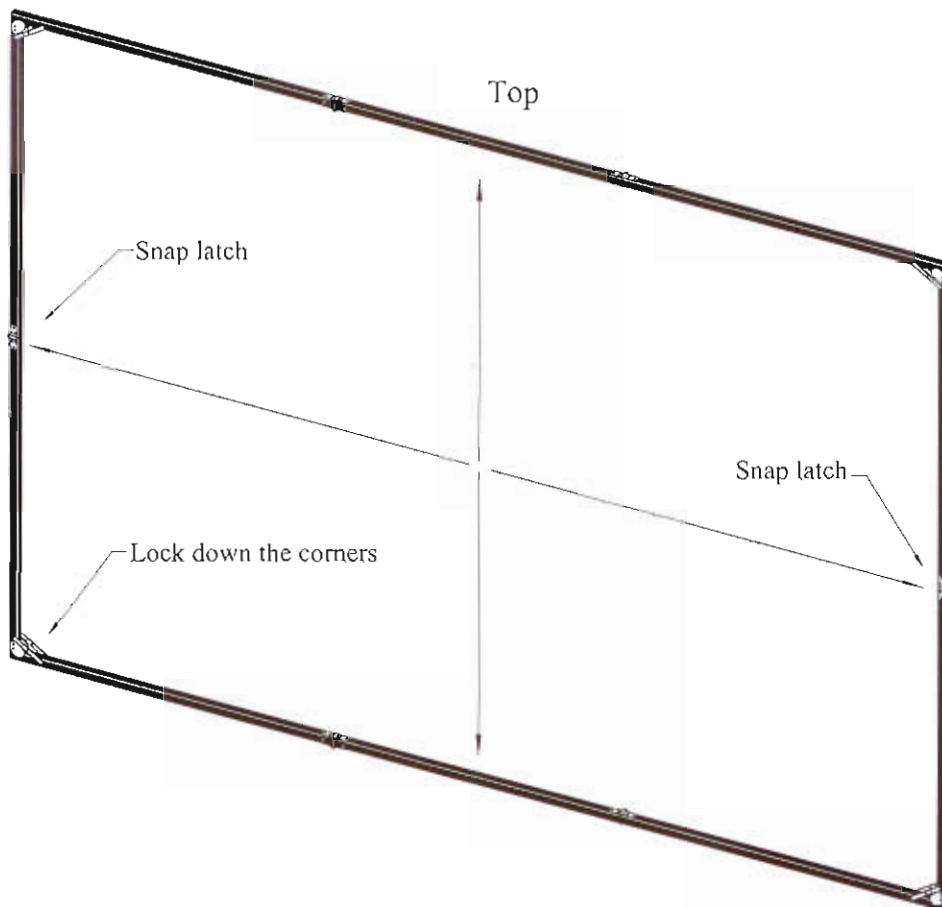

fig 6

Standard T-Leg

1. Remove the T-leg from its case and wrapping.
Position it as shown (fig 7).
2. Unfold the T-leg following the directions given below, Lock down all four corner braces (as fig 8).

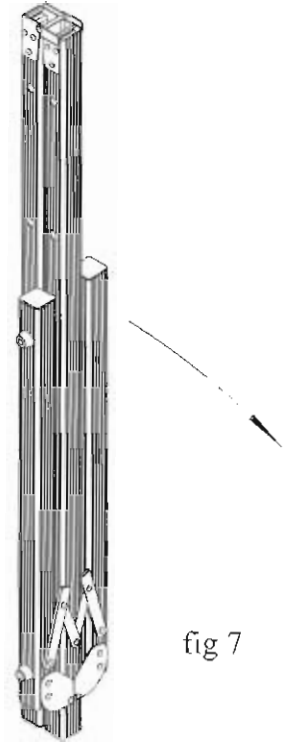

fig 7

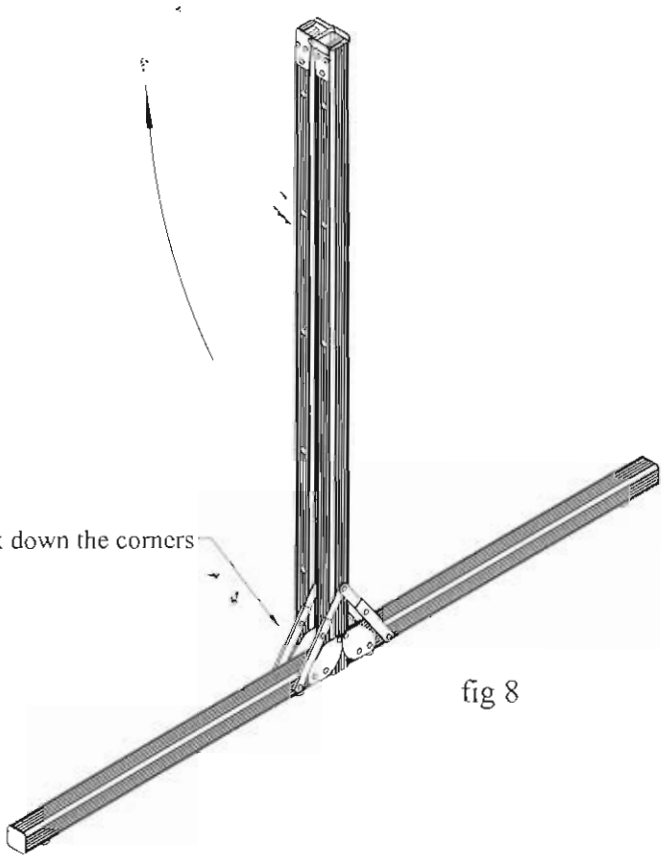

fig 8

3. Unfold the T-leg following the directions given upon, Snap latches will automatically lock (as fig 9).

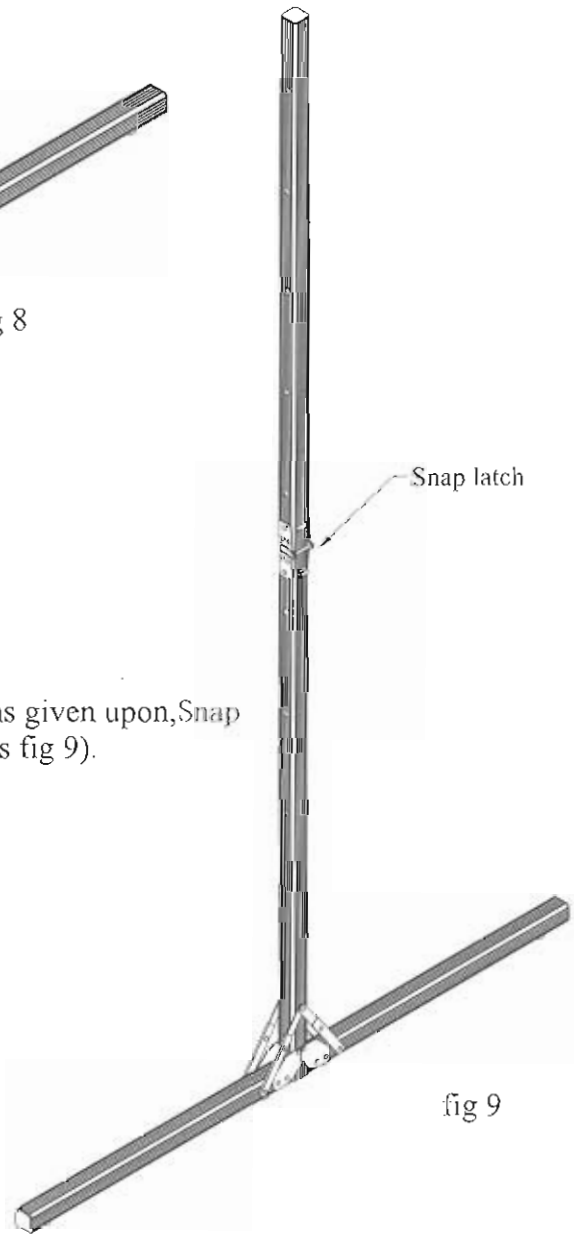

fig 9

AT-Leg (Recommended for added stability on size VS150" and over)

1. Remove the AT-leg from its case and wrapping (as fig 10).
2. Unfold the AT-leg following the directions given below, Snap latches will automatically lock (as fig 11).
3. Attach AT-leg to T-leg using 4 speedy cranks per leg (as fig 12).

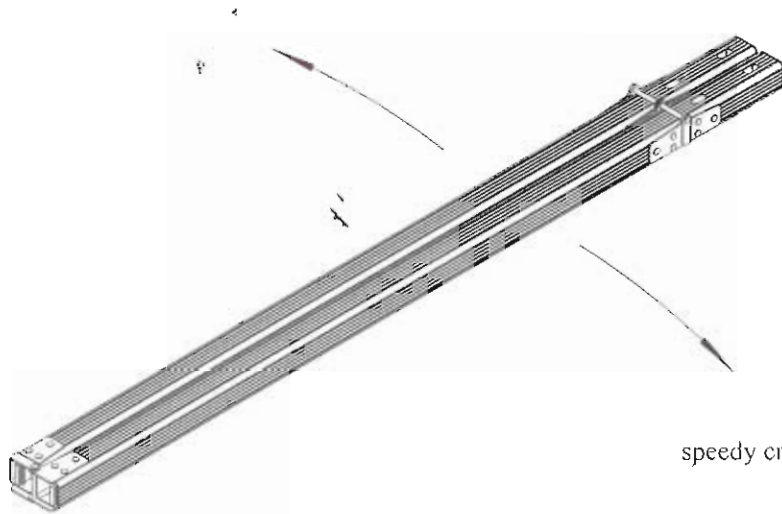

fig 10

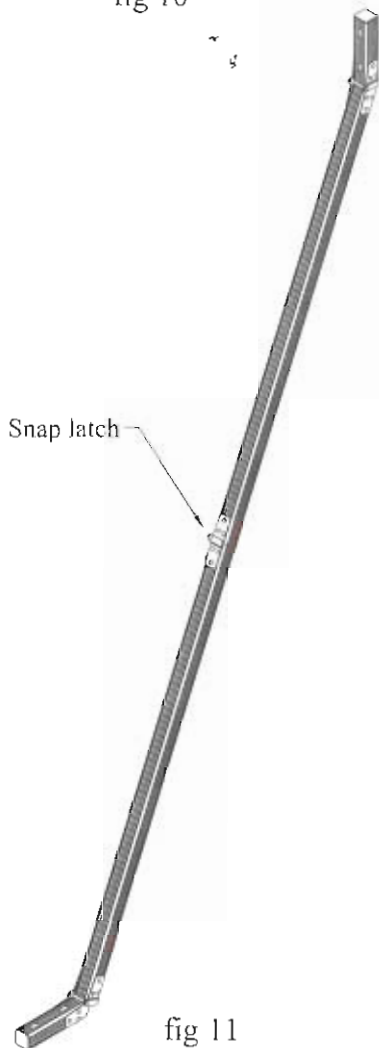

fig 11



fig 12

SAT-Leg (Recommended for added stability on size VS180" and over)

1. Remove the SAT-leg from its case and wrapping (as fig 13).
2. Unfold the SAT-leg (as fig 14).
3. Attach SAT-leg to T-leg using 4 speedy cranks per leg (as fig 15).

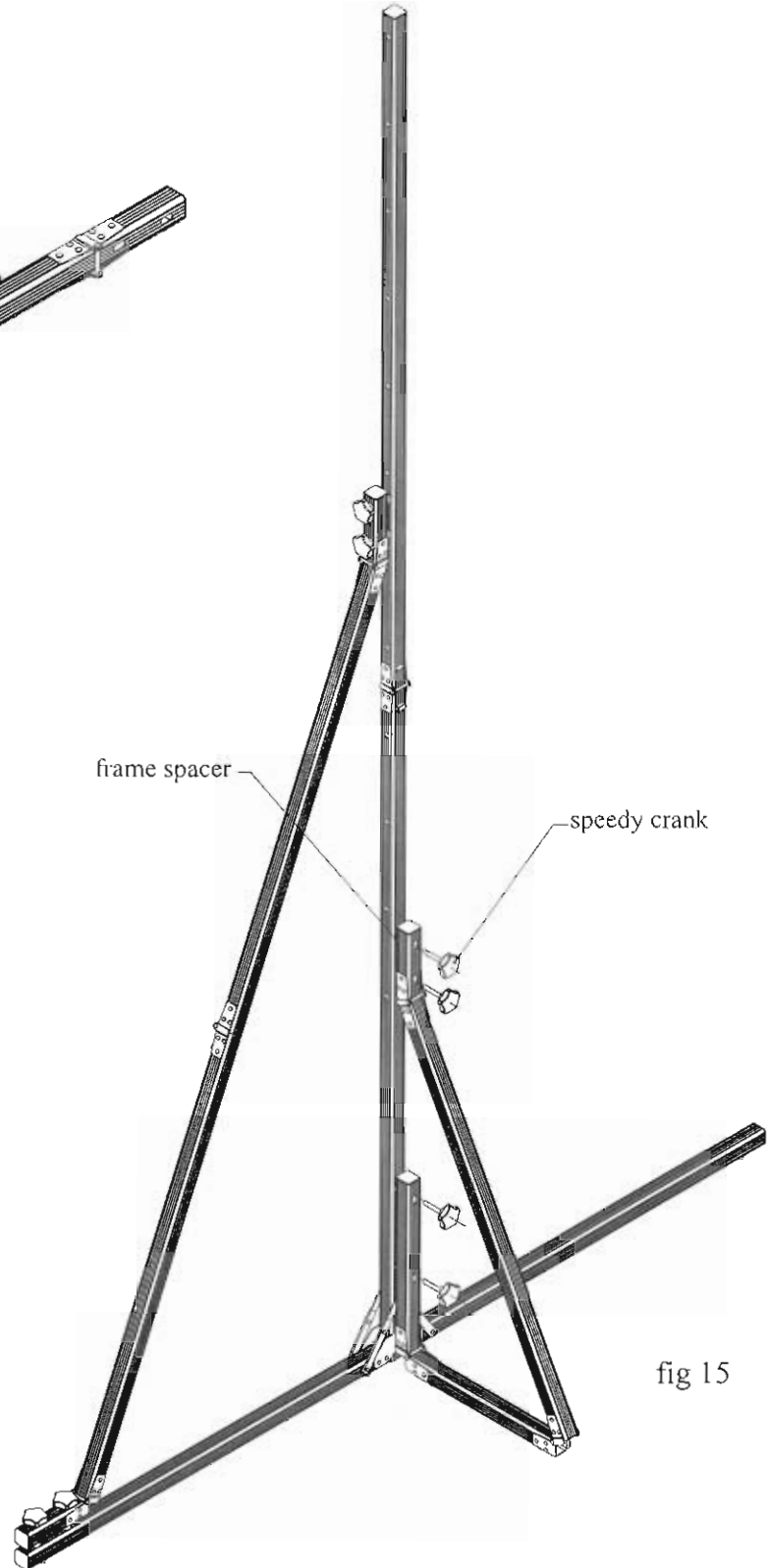
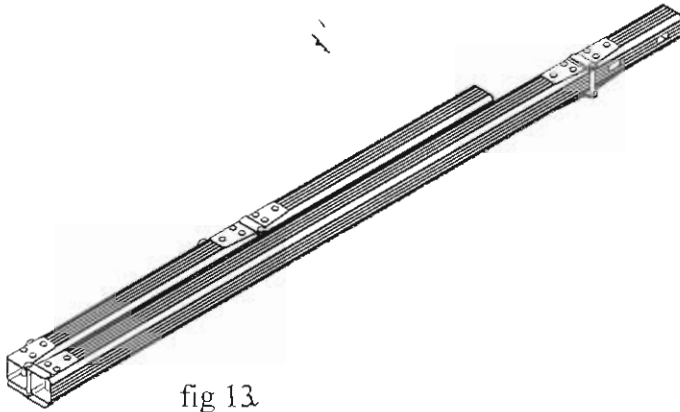

4. Attach leg to each side of frame using at least 2 speedy cranks per leg.

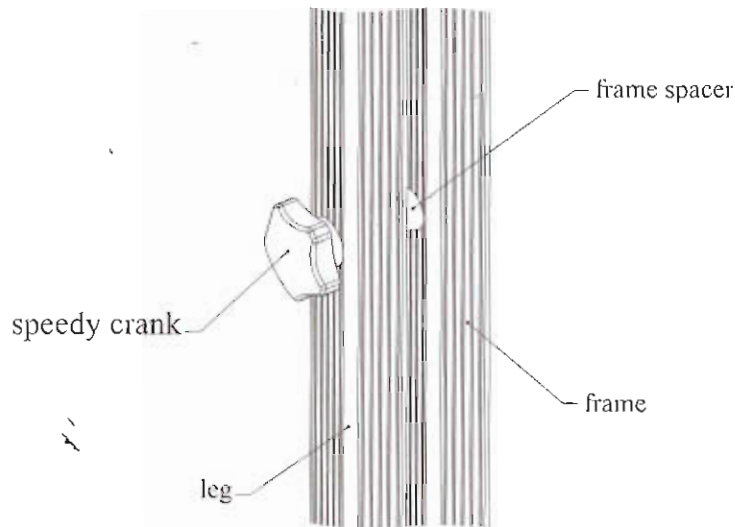

5. Height adjustment. Height is adjustable in 8" increments either up or down. Normal screen height is 44" from bottom of frame to floor.

6. To fold frame, unlock all four corner braces. Push the snap latch buttons and fold the frame.

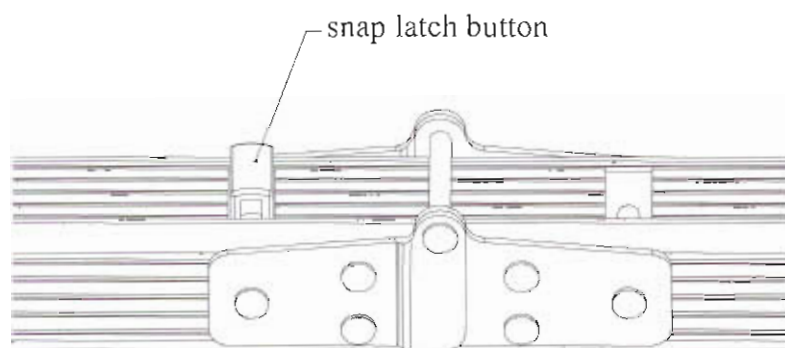

PACKING LIST

1. Frames	1 pcs
2. Legs	2 pcs
3. AT-Legs	2 pcs (option)
4. SAT-Legs	2 pcs (option)
5. Screen fabric	1~2 pcs
6. Speedy crank	6~26 pcs
7. Frame spacer	6~26 pcs
8. Manual	1 pcs

FOLDING THE PICTURE SURFACE FOR PACKING

When folding the screen material for packing, observe the following precautions before proceeding:

1. The surface should not be allowed to contact painted, varnished or plastic finished objects for a prolonged period of time.
2. Make certain the picture surface is on a clean, flat surface.

Then proceed in the following manner:

Place clean white tissue paper with no printing on top of the picture surface. If tissue is not available, a soft white cloth or something similar will serve the same purpose. Under no conditions should newspaper or anything similar be used since these may damage the screen material.

1. With the viewing side facing up, fold the fabric in half from top to bottom. Make certain when folding, the surface does not come in contact with either the black binding, grommets or snap buttons.
2. If the material on the first fold is more than 3 feet high, then fold once again, but always place clean tissue paper between the folds.
3. For large size screens, fold in half again if necessary. Make certain when folding, the surface does not come in contact with either the black binding, grommets or snap buttons.
4. After the top to bottom folding procedure is completed, then fold from left to right and continue folding until the fabric is of sufficient size to fit into the leatherette case.

NOTE: Keep the screen surface in the envelope provided when it is not in use. Failure to observe these normal precautions may cause discoloration of the material.

CLEANING

Surfaces can be cleaned as follows:

Using a white clean cloth (100% cotton preferred) that is dampened with clear water, gently wipe the area in one direction. Do not use a circular motion. Using a dry 100% cotton cloth, wipe dry after each cleaning session. To clean a stubborn stain or a sticky surface, use denatured alcohol (methanol or methyl alcohol) following the same procedure as for water.

NOTE: Screens are shipped with tissue paper packed between the folds. This keeps the material from sticking to itself and makes it easier to unfold.